



JCM 800 Series Surge Suppressor INSTALLATION INSTRUCTIONS

Failure to follow installation instructions will result in
voided product warranty.

To complete this installation, the following accessories are required and are not included:

- **Mounting Fitting** - i.e. flanged tapping sleeve (for flanged connections) or cut-in mechanical joint tee with appropriate connection outlet.
 - **For flange connections** - full face flange gasket and appropriate flange assembly hardware.
 - **For mechanical joint connections** - standard MJ gasket and appropriate MJ assembly hardware.
1. Install mounting fitting in/on run of pipeline. Position connection opening of mounting fitting on top (vertical) of pipe. Remove any rocks, sand and other job site debris that would prevent the gasket from seating in/on the connection opening.
 2. For flanged connections, install full face flange gasket. For mechanical joint connection, install mechanical joint gasket (gaskets are not included). Inspect gaskets for any nicks, gouges or tears. Slight lubrication of the gasket with soapy-water mixture will ease installation of fitting.
 3. Install Surge Suppressor on mounting fitting matching the connection stem on suppressor to the mounting fitting (mechanical joint or flanged). Surge Suppressor should be installed on the vertical of the pipe. (See reverse diagram 3 & 4) Appropriate blocking under the mounting fitting and surge suppressor is required. Improper support can result in undo stress.
 4. Double check the length of flange/MJ connection bolts and confirm proper length for installation. Install flange bolts/mechanical joint connection bolts. Hand tighten bolts and confirm even compression of the gasket.
 5. Tighten connection bolts to minimum 90 ft. lbs. torque making sure the gap between the two flanges is equally spaced around the outlet. Continue to tighten bolts in a "star" pattern, repeating the process until proper torque is reached. Place the 1/2" load bearing set pins in tapped holes and tighten set pins to minimum of 50 ft. lbs of torque. JCM recommends the use of a torque wrench to ensure proper torque levels are reached.
 6. Confirm that the threaded outlet plug is tightened to 50 - 70 ft. lbs. of torque. Tighten if necessary, Threaded outlet is utilized for fabrication process; plug may loosen during shipment.
 7. Confirm watertight application of all components. When testing the assembly the application should be treated with caution to prevent damage due to thin wall, flexible or brittle pipe conditions. Inspection and verification of the pipe integrity is the responsibility of the end user. For inquiries, contact JCM Industries, Inc.

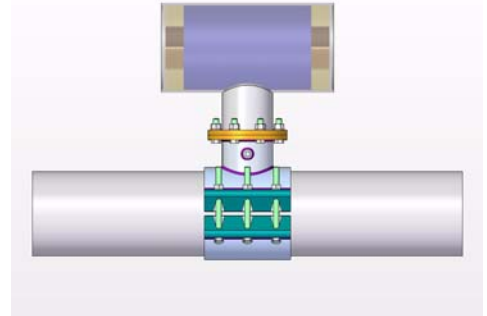

Note: See reverse for diagrams.

Installation Trick of the Trade:

To prevent damage to the unit during future excavation operations, permanently mark the curb & street location of the unit, or record the location in the distribution system mapping program.



JCM 800 Series Surge Suppressor INSTALLATION INSTRUCTIONS

Failure to follow installation instructions will result in voided product warranty.

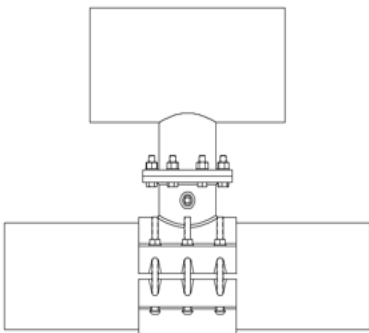
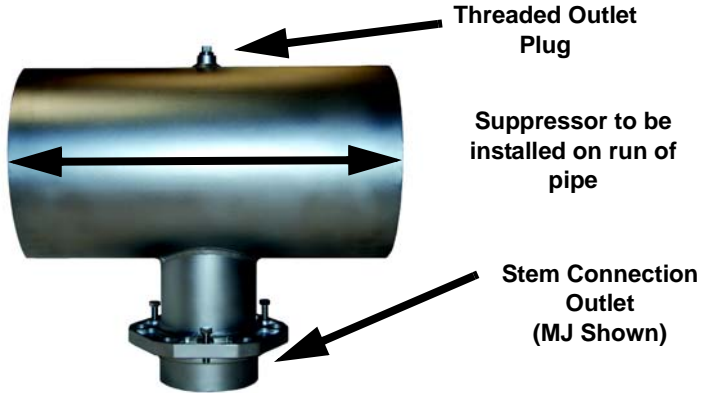

Diagram 3
Flanged Stem Connection

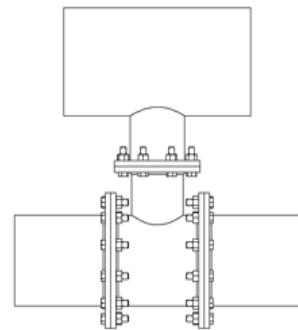
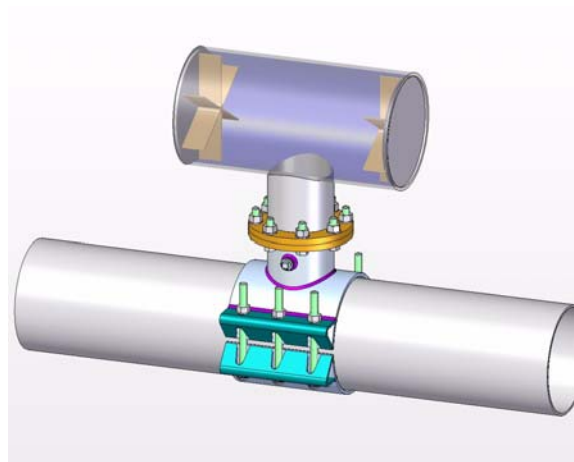

Diagram 4
MJ Stem Connection



Typical Installation
Flanged Stem Connection

INT800-1008