

JCM INDUSTRIES

P. O. Box 1220, Nash, TX 75569-1220
Phone 800-527-8482 or 903-832-2581
Fax 800-874-9524 or 903-838-6260
www.jcmindustries.com

Typical Specification

JCM 301 Ductile Iron Flanged Coupling Adapters

Flanged Coupling Adapters 3" - 12" shall be of a design which utilizes separate flange and coupling end gaskets, same number of bolts on coupling end as flange end. FCA flange shall be ductile iron with ANSI Class 125 & 150 bolt pattern, suitable for use with the standard and wafer type valves. Flanged Coupling Adapter shall be of ductile iron construction. Flanged Coupling Adapter shall be JCM 301 or approved equal.

JCM 300 Series Flanged Adapters are ANSI/NSF Standard 61, Annex G and ANSI/NSF 372 Certified.

JCM 300 Series Flanged Adapters meet or exceed the ANSI/AWWA C-219 Standard as applicable.

Note: For applications with High Density Polyethylene Pipe, refer to the JCM HDPE Fittings Manual or contact JCM Industries.



JCM 301 Flanged Coupling Adapter

This typical specification, provided by JCM Industries, is a proposed guideline for use by specifying agencies to ensure significant design and material features of this product are included within the agencies' individual specifications.



JCM INDUSTRIES

P. O. Box 1220, Nash, TX 75569-1220

Phone 800-527-8482 or 903-832-2581

Fax 800-874-9524 or 903-838-6260

www.jcmindustries.com

Material Specification

JCM 300 Series Flanged Coupling Adapters – 301

- Sleeve & Flanges: Sleeve - Ductile Iron Per ASTM A536 80-55-06.
Flange - Ductile Iron with ANSI Class 125 & 150 bolt pattern
- Gaskets: Styrene-Butadiene Rubber (SBR) has good physical properties. Compounded for use with water, salt solutions, mild acids and bases; has excellent abrasion resistance. Per ASTM D-2000. Standard temperature range from -40° to 150°F (-40° to 65° C) constant, maximum intermittent 180° F (82 ° C). For applications on high temperatures or chemical pipelines, contact JCM Industries Technical Services. The material is not recommended for use on oil, ozone or weather resistant applications.
- Bolts: 5/8" Corrosion resistant, high strength low alloy oval neck track head bolts per ASTM A242/ANSI 21.11/AWWA C111 and heavy hex nuts per A563 or equal.
Optional Hardware: Stainless Steel 18-8 Type 304 or 316
Epoxy Coated Alloy Hardware, Powercron 590-534 black cationic electrocoat.
- Coating: Corrosion resistant shop coat paint primer. Optional fusion applied epoxy coating per ANSI/AWWA C-213. Other coatings available upon request.
- Working Pressure: Fittings are rated for 150 PSI working pressure when installed per manufacturer's instructions. Inspection of pipe integrity is the responsibility of the end user. For higher working pressure applications, contact JCM Industries.

JCM 300 Series Flanged Adapters are ANSI/NSF Standard 61, Annex G and ANSI/NSF 372 Certified.

JCM 300 Series Flanged Adapters meet or exceed the ANSI/AWWA C-219 Standard as applicable.



Effective 01.30.19

JCM INDUSTRIES

P. O. Box 1220, Nash, TX 75569-1220
 Phone 800-527-8482 or 903-832-2581
 Fax 800-874-9524 or 903-838-6260

www.icmindustries.com

JCM 301 Flanged Coupling Adapter Design Specifications

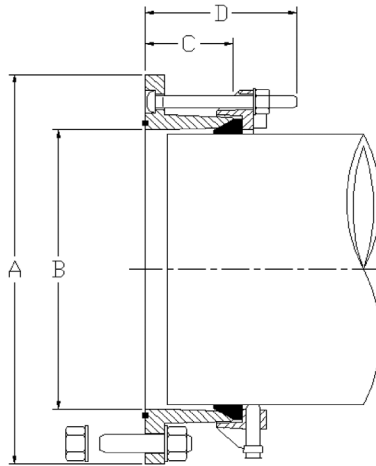

Nominal Pipe Size	A (IN)	B (IN)	C (IN)	D (IN)
3	8-1/8	4-1/4	3	5-1/2
4	9-1/8	5-1/4	3	5-1/2
6	11-1/8	7-5/16	3-1/2	5-1/2
8	13-1/2	9-9/16	3-1/2	5-1/2
10	16-1/4	11-9/16	4	7
12	19	13-5/8	4	7

Note: Applications in which the pipe may move out of the coupling, proper anchorage of the pipe must be provided.