

JCM

JCM 116 Repair Sleeve for Concrete Steel Cylinder Pipe Installation Instructions

Read Entire Instruction Set Before Installing Sleeve

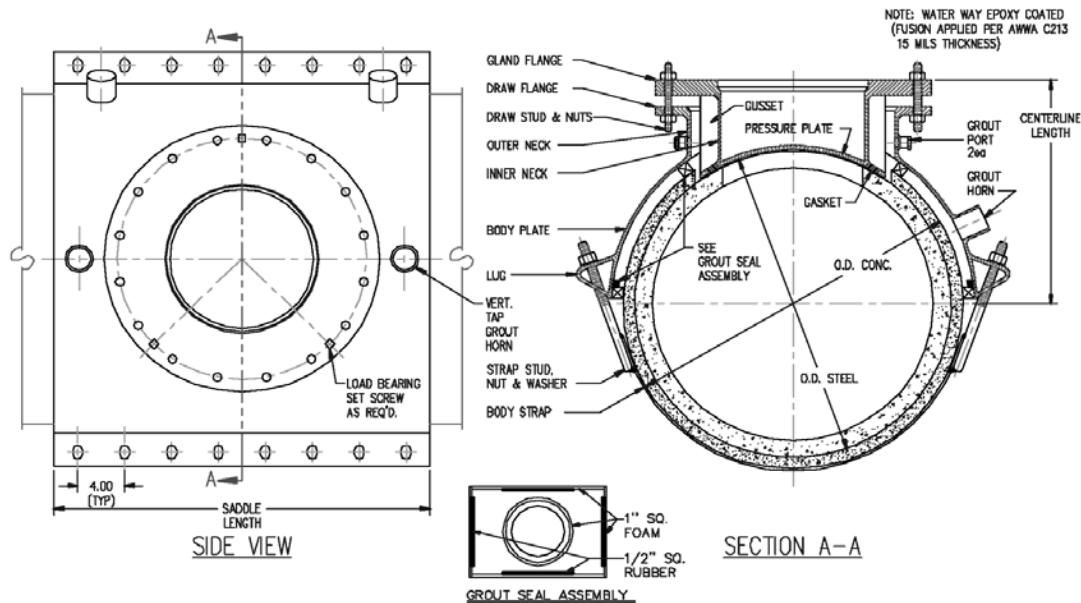

1. Clean pipe in area where sleeve is to be installed. Remove any irregularities extending beyond the normal contour of the pipe surface. Check all measurements to be certain sleeve is correct size for the pipe.
2. Position gland over the damaged area on the pipe and mark area where mortar coating is to be removed.
3. Remove gland and set aside. Carefully remove mortar coating from area where repair is to be made - exposing but not further damaging the prestress wires and steel cylinder.
4. Check to make certain all grout gaskets are in place around the edge of the sleeve and around the outlet. Place the sleeve on the pipe with the outlet over the opening in the mortar coating and install the straps. Tighten the straps with only sufficient torque to lightly seal the grout gaskets, alternating from one side of the sleeve to the other - starting at the outside straps and working in toward the center.
5. Move the grout horn caps to grout horns which are **not vertical**. Pour cement grout into the grout horns in the sleeve filling the space between the sleeve and the pipe. Pound the sleeve with a hammer to vibrate grout into place. After the grout has set, tighten bolts on straps to the following torque values:

Sleeves through 42" nominal

70 - 90 Ft/Lbs

Sleeve sizes 48" and larger

95 - 125 Ft/Lbs

(Note: Torque given is based on clean and lightly lubricated threads.)

INT116-0506

JCM Industries, Inc. / P. O. Box 1220 / Nash, TX 75569-1220



**JCM 116 Repair Sleeve For
Concrete Steel Cylinder Pipe
Installation Instructions
(continued)**

6. Carefully cut and remove the exposed prestress wires to provide clearance for the gland to seal against the cylinder. For embedded cylinder pipe, the outer portion of the concrete core must be removed to expose the cylinder. Clean steel cylinder surface of any remaining concrete. (Note: If there is a weld seam on the cylinder of the pipe in the area of the tap, carefully flatten the weld so that the repair gland will seal on it.)
7. Check the gasket in the gland to make certain it is undamaged and in its retaining groove. Remove any tape used to secure gasket in place during shipment.
8. Install the four (4) threaded studs in the sleeve outlet to assist in properly aligning the gland. Install the gland in the sleeve outlet so the contour of the gasket seat exactly matches the contour of the steel cylinder. Install the remainder of the draw bolts. Check the gasket seat alignment. Tighten the draw bolts evenly to compress the gasket onto the steel cylinder.
9. After installation of the repair gland, tighten the load bearing set screws located between the draw bolts of the outer bolt circle. This locks the gland in place and transfers any loading from the outlet onto the sleeve and away from the cylinder.
10. On completion of the repair, pour cement mortar (2 parts sand, 1 part cement) into the opening between the gland and the saddle and into the grouting hole in the sleeve neck completely filling the space around the gland. A protective coating of cement mortar concrete to a minimum thickness of 1" over the entire assembly including straps will further protect the sleeve.